

# HRI-R22t series

INSULATION MONITORING  
VERSIONS FOR USE IN MEDICAL ROOMS

## GENERAL

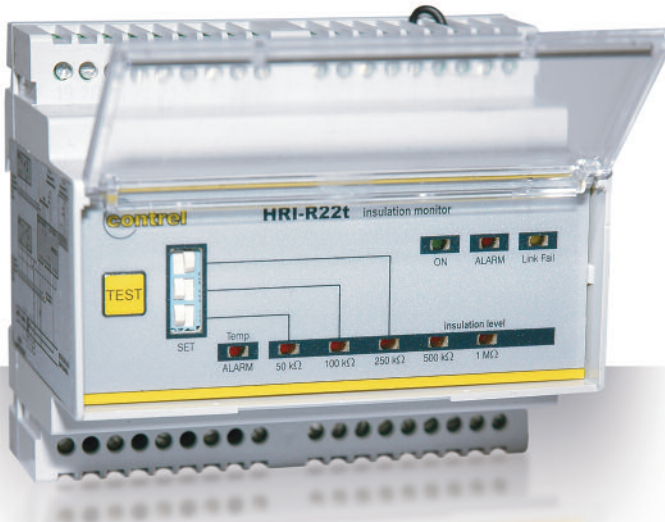

### HRI-R22t series

The device has similar characteristics of previous model but it's more cheap and it has less functions.

There is measuring signalling and it is able to verify temperature of insulation' power transformer (1 PTC input with contact NO or NC directly supplied by device) and insulation's level.

These inputs are available: for remote repeaters panels PR2 and PR2-t and 1 relay NO-C-NC, that is activate when fixed threshold (insulation and temperature) are over-ride. HRI-R22t has frontally a bar led for visualising insulation's level of device and eventual alarm's presence is visualised frontally by led.

Testing button is available and it works for monitoring insulation's level preset with calibration on relay (for example, with 50 kohm calibration all the led with inferior limit of 50 kohm will light during the test).

This button monitors eventual remote reply panels PR-5 (max 2 panels).

## FUNCTIONS AND OPERATORS - LEGEND

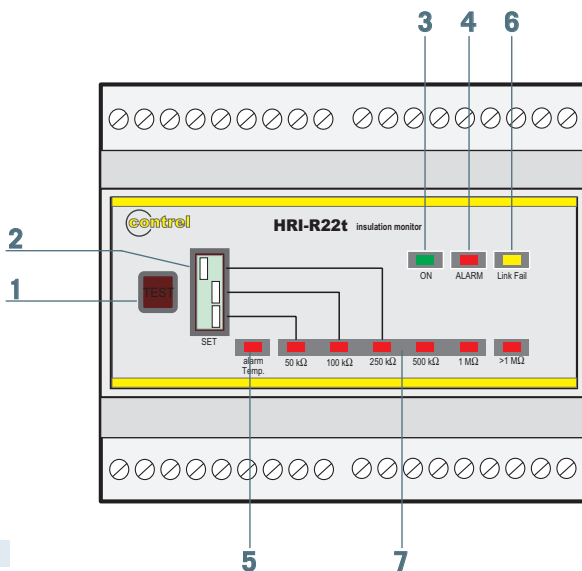

### 1 TEST PUSHBUTTON

### 2 MICRO SWITCH for threshold set

- turning the switch to right, corresponding insulation's resistance degree has to be digit, highest degree heads
- with all the switches turned to left, fixed degree of 50 kohm doesn't change

### 3 LED signalling supplied relay

### 4 LED signalling pre-fixed insulation's threshold reached

### 5 LED signalling temperature's threshold reached

### 6 LED signalling relay connected correctly

### 7 LED signalling instant insulation's value of device, identified by lowest degree between active led

## ELECTRIC CHARACTERISTICS

TYPE	HRI-R22t
Auxiliary supply	230 V $\pm$ 20%
Frequency	50 $\div$ 60 Hz
Self-consumption	3 VA
Unde-control network voltage	24 $\div$ 230 V 50 $\div$ 60 Hz
Voltage's measure	< 15 V
Current's measure	< 0.6 mA
Internal impedance for resistive measure	1 Mohm
Selectable trip threshold	50-100-250 kohm (low insulation) by switches
Visualisation	led of insulation value by led bar 50 $\div$ 1000 kohm led of signalling network's presence led of signalling low insulation led of signalling over-temperature led of failed insertion signalling
Output	for panel PR5 (max 2) total + 1 contact NO-C-NC 5 A - 250 V (low insulation) + 1 contact NO-C-NC 5 A - 250 V (over-temperature)
Input	from isolated network 230 Vac (insulation measure) PTC probe (temperature measurement)
Voltage of signal circuit	< 24 Vdc
Measure's method	signalling dc
Insulation's test	2.5 kV 60 sec
Working temperature	-10 $\div$ 60 °C
Storing temperature	-20 $\div$ 80 °C
Relative humidity	MAX 90 %
Standard regulation	CEI-EN 61010-1 / CEI-EN 61557-8 / VDE 0413 part.8 CEI 64.8/7-710 V2 / IEC 60364-7-710 / UNE 20615 / CEI-EN 61326-1
Assembling according to DIN 50022	snap on DIN rail 35 mm
Dimensions	6 modules DIN 17.5 mm
Protection's degree	IP50 frontal - IP20 case
Connections	by screw terminals max 2.5 mm <sup>2</sup>

## DIMENSIONS

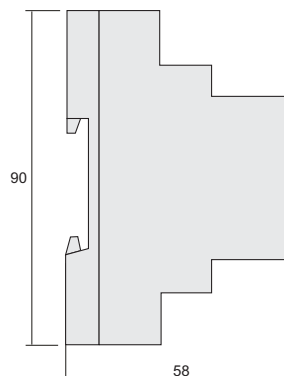
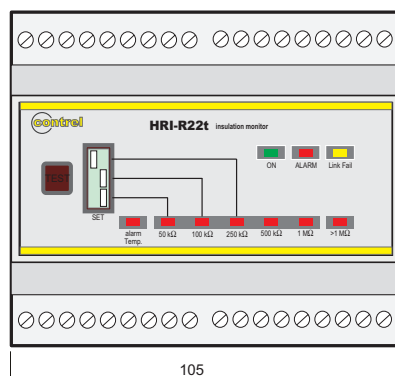

## WIRING DIAGRAMS - LEGEND

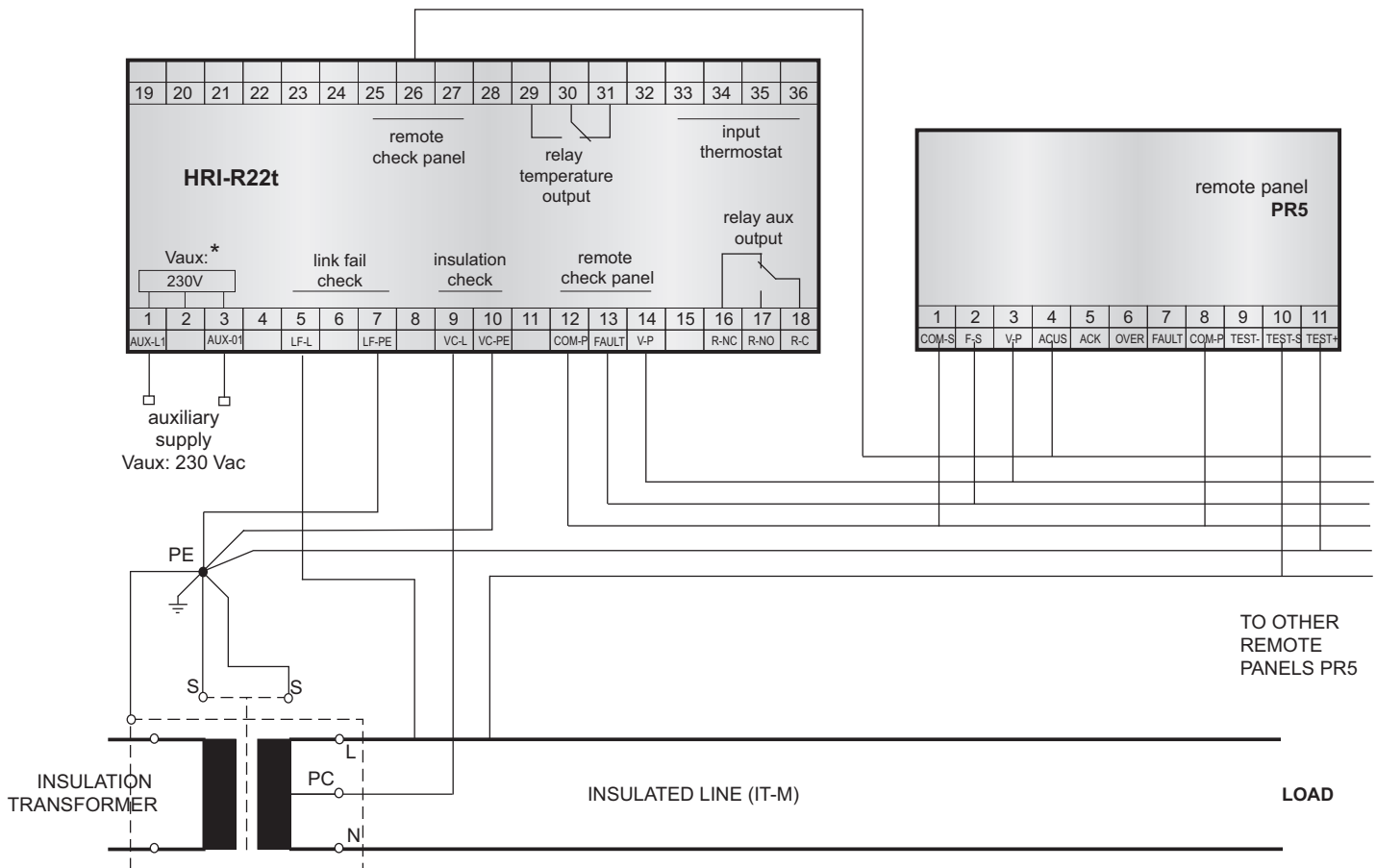

### AUXILIARY SUPPLY - TERMINALS 1-3

### MONITORING INSULATION - TERMINALS 5-9

both terminals have to be connected between centre tap of secondary transformer or isolated network's phase and unipotential node (PE). Maximum voltage applicable is 230 Vca. Consequentially single phase networks could be maximum 230 V, three phase networks of three wires is 230 V phase-phase but three phase networks four wires is max 230 V phase-neutral

### CONNECTIONS FOR REMOTE PANELS PR5 - TERMINALS 12-13-14-26

### INPUT THERMAL PROBE - TERMINALS 33-34 or 35-36.

PTC (DIN 44081) probe could be used

### AUXILIARY RELAY OUTPUT - TERMINALS 29-30-31

contact in switch voltage-free with programmable functions. Contact's capacity 250 V 5 A resistive load