

# ELRC-BL | ELRD-L | ELRD-L2m

EARTH LEAKAGE RELAY - MODULAR VERSION 6 MODULES (PUBLIC LIGHTING)



## GENERAL CHARACTERISTICS

- Earth leakage relay type A
- Automatic trip and reclosing
- External toroidal (ELRD-L, ELRD-L2m only)
- Incorporated toroidal Ø28mm (ELRC-BL only)
- Green power LED indicator (ON)
- Red relay tripped LED indicator (TRIP)
- Red tripping prealarm LED indicator (ALARM) (ELRD-L2m only)
- Front TEST and RESET buttons
- Configurable automatic or manual resetting
- Flag indicator (TRIP MEMORY) (ELRD-L2m only)
- Modular DIN housing, 6 module, with transparent cover
- Degree of protection: IP20 terminals, IP40 on front with cover

ORDER CODE	RATED AUXILIARY SUPPLY VOLTAGE	OUTPUTS CONTACTS	WT [kg]
ELRC-BL	240 VAC	2	0,370
ELRD-L	240 VAC	2	0,390
ELRD-L2m	240 VAC	2	0,390

OPTIONS	
T	Tropicalisation

ADJUSTMENTS PER	ELRC-BL	ELRD-L	ELRD-L2m
Configurable tripping set-point ( $I\Delta n$ )	0,025...0,25A 0,25...2,5A 2,5...25A 25...250A (with external multiplier CT1-M)		
Set-point prealarm		fixed 70% (ELRD-L2m only)	
Configurable tripping delay time (t)	0,02...0,5s 0,2...5s.		
Self-closing attempts	3 or 6 consecutive (version ELRC-BL)	3 consecutive (version ELRD-L, ELRD-L2m)	

## MECHANICAL DIMENSIONS

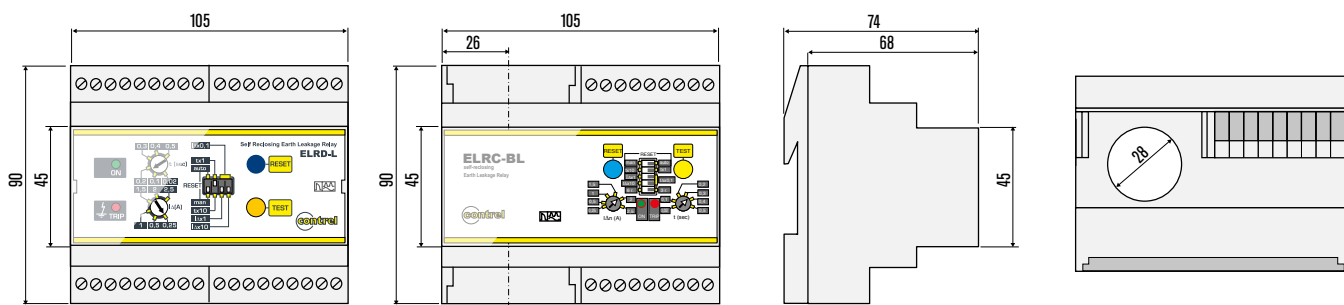

# ELRC-BL | ELRD-L | ELRD-L2m

EARTH LEAKAGE RELAY - MODULAR VERSION 6 MODULES (PUBLIC LIGHTING)

TECHNICAL CHARACTERISTICS	ELRC-BL	ELRD-L	ELRD-L2m
<b>CONTROL CIRCUIT</b>			
Toroidal transformer	External (version ELRC-BL Incorporated Ø 28 mm)		
Adjustments tripping set-point (I $\Delta$ )	0.025÷25A		
Adjustments tripping time (t)	0.02÷5s		
Set-point prellarme	70% I $\Delta$ n (fixed) (version ELRD-L2m)		
Numero tentativi di ripristino	3 o 6 consecutive	3 consecutive	3 consecutive
<b>AUXILIARY SUPPLY</b>			
Auxiliary voltage (Us)	240 VAC		
Rated frequency	50-60 Hz		
Maximum power consumption	4 VA		
<b>OUTPUT RELAYS</b>			
Contact arrangement	2 changeovers (both trip)	2 changeovers (1 trip, 1 alarm)	2 changeovers (1 trip, 1 alarm)
Rated contact capacity Ith	5 A (240 VAC)		
<b>INDICATIONS</b>			
Auxiliary voltage available (ON)	Green LED		
Relay tripping (TRIP)	Red LED		
Alarm advance (ALARM)	red LED (versions ELRD-L, ELRD-L2m)		
Mechanical flag (TRIP)	Flag indicator (version ELRD-L2m)		
<b>INSULATION</b>			
Insulation test	2.5kV for 1 minute		
<b>AMBIENT OPERATING CONDITIONS</b>			
Operating temperature	-10÷60 °C		
Storage temperature	-20÷80 °C		
Relative humidity	≤90%		
<b>ENCLOSURE</b>			
Version	6 modules DIN		
Degree of protection	IP20 terminals   IP40 with protective cover		
<b>CERTIFICATIONS AND COMPLIANCE</b>			
Reference standards	IEC/EN 61010, IEC/EN 61000-6-2	IEC/EN 61000-6-3, IEC/TR 60755	CEI EN 60947-2 Annex M

## WIRING CONNECTION ELRC-BL

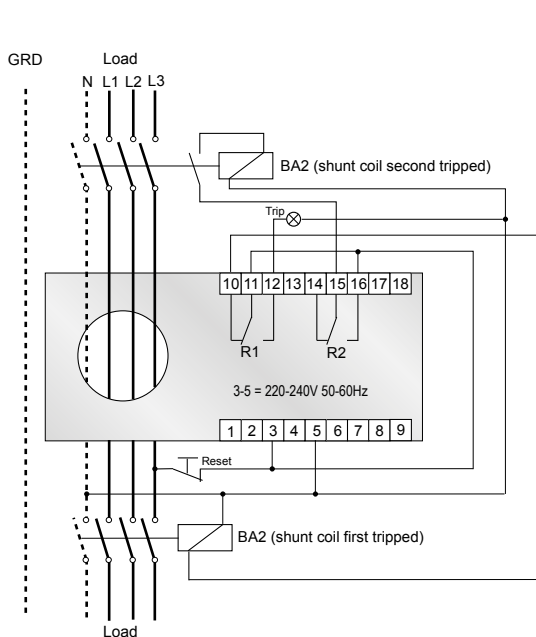

## WIRING CONNECTION ELRD-L | ELRD-L2m

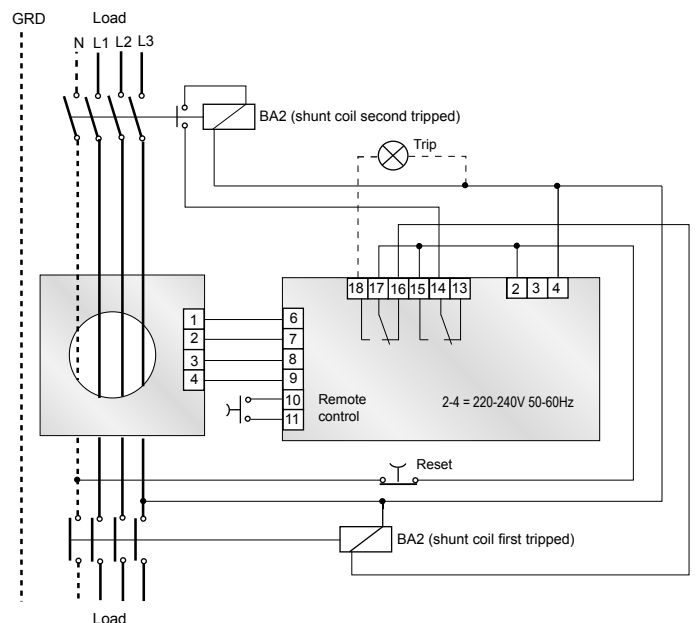

# ELRC-BL | ELRD-L | ELRD-L2m

EARTH LEAKAGE RELAY - MODULAR VERSION 6 MODULES (PUBLIC LIGHTING)

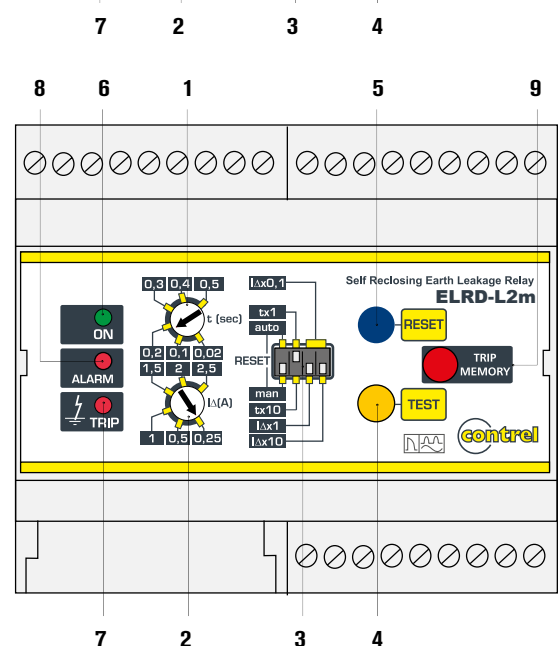
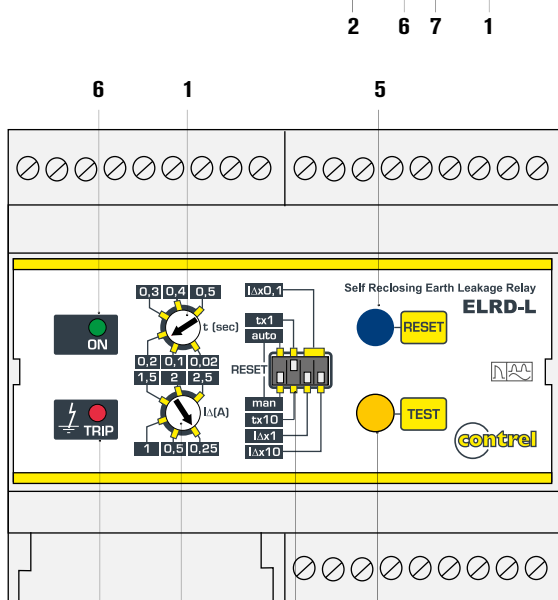
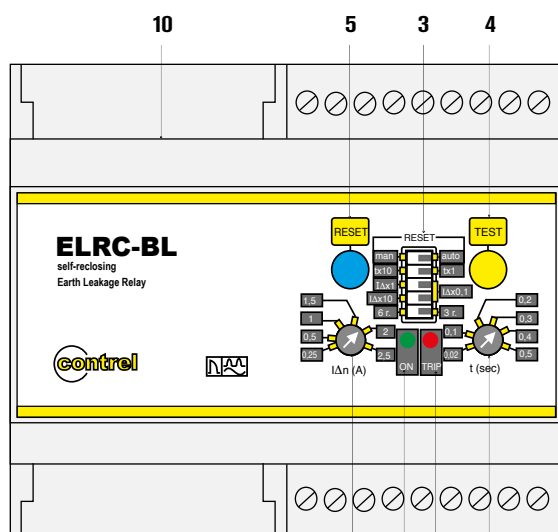

LEGENDA	
1	Tripping delay time adjustment
2	Fault current to earth adjustment
3	<p>Dip switches settings:</p> <p><b>3a</b> - auto reset (A) - man reset (M)                      auto reset = automatic reset                      man reset = manual reset through RESET key on the front. For remote resetting, simply shut off the auxiliary supply for about 1 second</p> <p><b>3B</b> - tx10 - tx1 constant selection for tripping delay time adjustment.                      Examples: positioning the dip switch on tx10 and the potentiometer on 0.3 we will have a tripping delay upon exceeding the <math>I\Delta n</math> threshold of <math>0.3 \times 10 = 3</math> seconds; positioning the dip switch on tx1 and the potentiometer on 0.3 we will have a tripping delay upon exceeding the <math>I\Delta n</math> threshold of <math>0.3 \times 1 = 0.3</math> seconds</p> <p><b>3C</b> - <math>I\Delta n \times 0,1</math> - <math>I\Delta n \times 1</math> - <math>I\Delta n \times 10</math> constant selection for fault current to earth adjustment. The constants in relation to the position of the 2 dip switches are the following:                      - dip switch position <math>I\Delta n \times 0,1</math> and <math>I\Delta n \times 0,1</math> K = 0.1                      - dip switch position <math>I\Delta n \times 1</math> and <math>I\Delta n \times 0,1</math> K = 1                      - dip switch position <math>I\Delta n \times 1</math> and <math>I\Delta n \times 10</math> K = 10</p> <p><b>3D</b> - Version ELRC-BL 6r - 3r selection for self-reclosing attempts                      6r = 6 self-reclosing attempts                      3r = 3 self-reclosing attempts</p>
4	TEST key. Causes tripping of the relay.
5	RESET key. To reset the relay after tripping. For remote reset, simply shut off the auxiliary supply for about 1 second.
6	ON LED. Indicates the presence of auxiliary voltage.
7	TRIP LED. Lighting up indicates the cutting in of the TRIP relay due to exceeding the $I\Delta n$ set.
8	ALARM LED ( <b>version ELRD-L2m</b> ) Lighting up depends on the dip switch programming; see the instructions of point 3a)
9	TRIP MEMORY ( <b>version ELRD-L2m</b> ) Mechanical trip relay indicator for exceeding the $I\Delta n$ set. It stores the indication also in the lack of auxiliary voltage. The flag indicator resetting can only be made with the RESET button.
10	Built-in current transformer. Hole diameter 28mm. It must be crossed by the cables of the line to be controlled; insert the phases and neutral if present. The earth cable must NOT cross the current transformer