

ELR-61 | ELR-m61 / ELR-62 | ELR-m62

EARTH LEAKAGE RELAY - MODULAR VERSION 6 MODULES



GENERAL CHARACTERISTICS

- Earth leakage relay type A
- External toroidal
- Green power LED indicator (ON)
- Red relay tripped LED indicator (TRIP)
- Red tripping prealarm LED indicator (ALARM) (ELR-62, ELR-m62 only)
- Front TEST and RESET buttons
- Configurable automatic or manual resetting
- Flag indicator (TRIP MEMORY) (ELR-m61, ELR-m61 only)
- Modular DIN housing, 6 module, with transparent cover
- Degree of protection: IP20 terminals, IP40 on front with cover

ORDER CODE	RATED AUXILIARY SUPPLY VOLTAGE	OUTPUTS CONTACTS	WT [kg]
ELR-61 48	24-48 VAC/DC	2	0,390
ELR-61 415	110-240-415 VAC	2	0,390
ELR-61 /10 Calibration up to 10 mA	110-240-415 VAC	2	0,390
ELR-m61 48	24-48 VAC/DC	2	0,390
ELR-m61 415	110-240-415 VAC	2	0,390
ELR-62 48	24-48 VAC/DC	2	0,390
ELR-62 415	110-240-415 VAC	2	0,390
ELR-m62 48	24-48 VAC/DC	2	0,390
ELR-m62 415	110-240-415 VAC	2	0,390

OPTIONS	
T	Tropicalisation
F	Built-in filter for 3rd harmonic (ELR-61 only)
SP	Configurable fail safe operation

ADJUSTMENTS	
Configurable tripping set-point (IΔn)	0,025...0,25A 0,25...2,5A 2,5...25A 25...250A (with external multiplier CT1-M)
Prealarm set-point	fixed 70% (ELR-62, ELR-m62 only)
Configurable tripping delay time (t)	0,02...0,5s 0,2...5s.

ELR-61 | ELR-m61 / ELR-62 | ELR-m62

EARTH LEAKAGE RELAY - MODULAR VERSION 6 MODULES

TECHNICAL CHARACTERISTICS	ELR-61 ELR-m61	ELR-62 ELR-m62
CONTROL CIRCUIT		
Toroidal transformer	External	External
Adjustments tripping set-point ($I\Delta$)	0.025÷25A (25÷250A with external multiplier)	0.025÷25A (25÷250A with external multiplier)
Adjustments tripping time (t)	0.02÷5s	0.02÷5s
Set-point prellarme	70% $I\Delta_n$ (fixed) (versions ELR-62, ELR-m62)	70% $I\Delta_n$ (fixed) (versions ELR-62, ELR-m62)
AUXILIARY SUPPLY		
Auxiliary voltage (Us)	24-48 VAC/DC 110 VAC/DC-240-415 VAC	24-48 VAC/DC 110 VAC/DC-240-415 VAC
Rated frequency	50-60 Hz	50-60 Hz
Maximum power consumption	4 VA	4 VA
OUTPUT RELAYS		
Contact arrangement	1 changeovers (TRIP)	2 changeovers (1 TRIP, 1 ALARM)
Rated contact capacity Ith	5 A (240 VAC)	5 A (240 VAC)
INDICATIONS		
Auxiliary voltage available (ON)	Green LED	Green LED
Relay tripping (TRIP)	Red LED	Red LED
Alarm advance (ALARM)	Red LED (versions ELR-m61, ELR-m62)	Red LED (versions ELR-m61, ELR-m62)
Mechanical flag (TRIP)	Flag indicator (versions ELR-m61, ELR-m62)	Flag indicator (versions ELR-m61, ELR-m62)
INSULATION		
Insulation test	2.5kV for 1 minute	2.5kV for 1 minute
AMBIENT OPERATING CONDITIONS		
Operating temperature	-10÷60 °C	-10÷60 °C
Storage temperature	-20÷80 °C	-20÷80 °C
Relative humidity	≤90%	≤90%
ENCLOSURE		
Version	6 modules DIN	6 modules DIN
Degree of protection	IP20 terminals IP40 with protective cover	IP20 terminals IP40 with protective cover
CERTIFICATIONS AND COMPLIANCE		
Reference standards	IEC/EN 61010, IEC/EN 61000-6-2	IEC/EN 61000-6-3, IEC/TR 60755 CEI EN 60947-2 Annex M

WIRING CONNECTION ELR-61 | ELR-m61

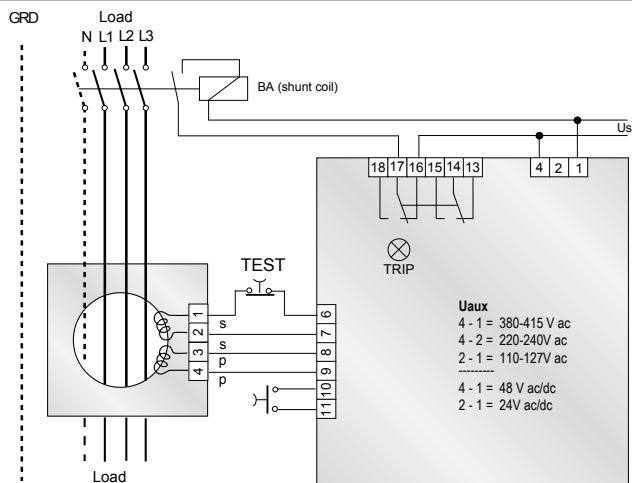

WIRING CONNECTION ELR-62 | ELR-m62

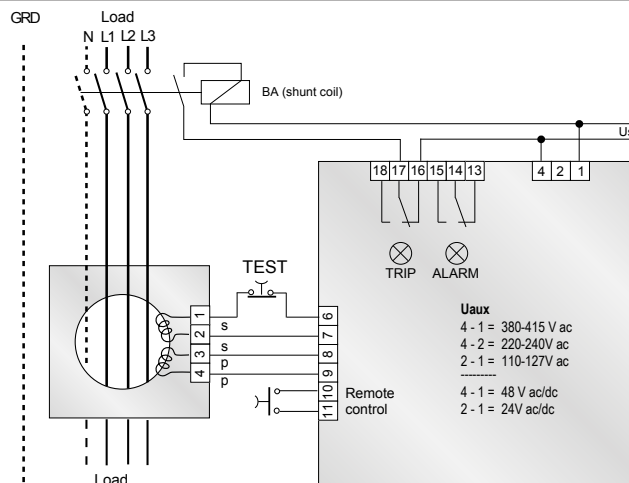

MECHANICAL DIMENSIONS

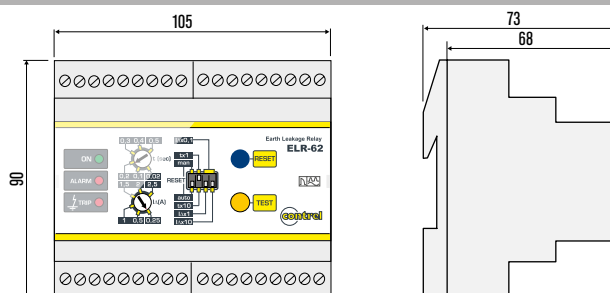

ELR-61 | ELR-m61 / ELR-62 | ELR-m62

RELÈ DIFFERENZIALI DI TERRA - ESECUZIONE MODULARE DIN

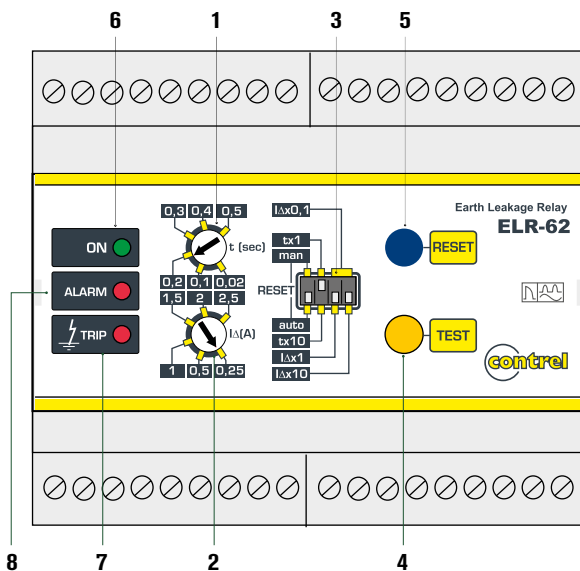
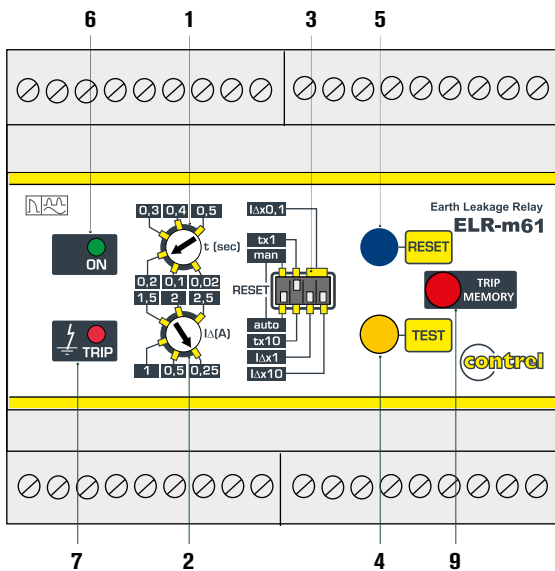
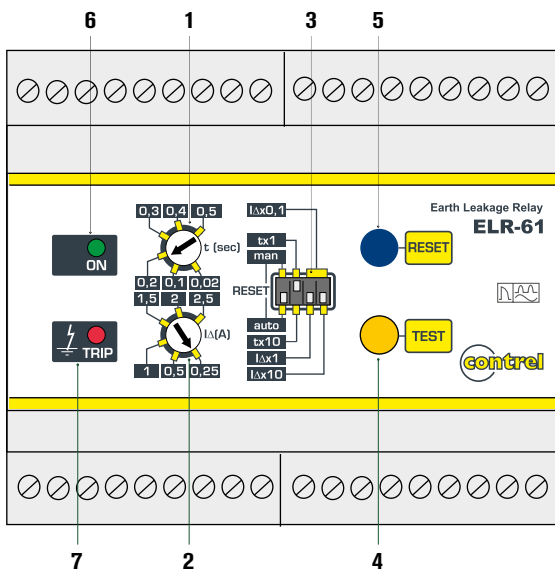

LEGENDA

1	Tripping delay time adjustment
2	Fault current to earth adjustment
3	Dip switches settings: 3a - auto reset (A) - man reset (M) auto reset = automatic reset man reset = manual reset through RESET key on the front. For remote resetting, simply shut off the auxiliary supply for about 1 second 3b - tx10 - tx1 constant selection for tripping delay time adjustment. Examples: positioning the dip switch on tx10 and the potentiometer on 0.3 we will have a tripping delay upon exceeding the $I\Delta n$ threshold of $0.3 \times 10 = 3$ seconds; positioning the dip switch on tx1 and the potentiometer on 0.3 we will have a tripping delay upon exceeding the $I\Delta n$ threshold of $0.3 \times 1 = 0.3$ seconds 3c - $I\Delta n \times 0.1$ - $I\Delta n \times 1$ - $I\Delta n \times 10$ constant selection for fault current to earth adjustment. The constants in relation to the position of the 2 dip switches are the following: <ul style="list-style-type: none"> • dip switch position $I\Delta n \times 0.1$ and $I\Delta n \times 0.1$ K = 0.1 • dip switch position $I\Delta n \times 1$ and $I\Delta n \times 0.1$ K = 1 • dip switch position $I\Delta n \times 1$ and $I\Delta n \times 10$ K = 10
4	TEST key. Causes tripping of the relay.
5	RESET key. To reset the relay after tripping. For remote reset, simply shut off the auxiliary supply for about 1 second.
6	ON LED. Indicates the presence of auxiliary voltage.
7	TRIP LED. Lighting up indicates the cutting in of the TRIP relay due to exceeding the $I\Delta n$ set.
8	ALARM LED (versions ELR-62, ELR-m62). lighting up depends on the dip switch programming; see the instructions of point 3a)
9	TRIP MEMORY (versions ELR-m61, ELR-m62). Mechanical trip relay indicator for exceeding the $I\Delta n$ set. It stores the indication also in the lack of auxiliary voltage. The flag indicator resetting can only be made with the RESET button.

